

Hydreon Rain Gauge Model RG-9

Technical Drawings found at rainsensors.com/rq-9-15-drawings

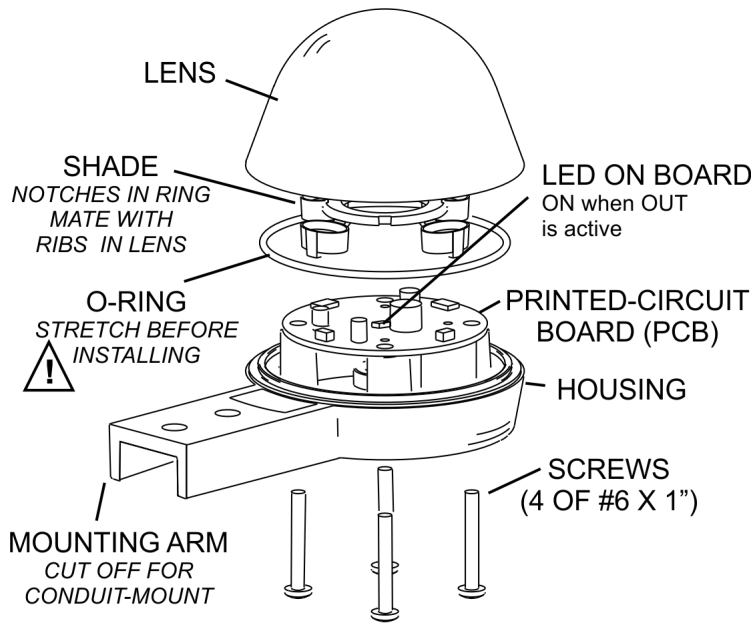

EXPLODED VIEW

Specifications

Parameter	Value
Input Voltage	Range 5-16 VDC on J1 Reverse polarity protected to 50V <i>Alternative</i> 3.3V though pin 8 on J2. Note if this isn't a stable supply it could induce false indications or affect accuracy. An overhtml voltage to this pin will destroy the device.
Current Drain ¹	110 µA nominal. (No outputs on, dry not raining) 2-4 mA when raining
Output	NPN Open Collector Output 100 mA / 80V Max
Operating Temperature range	-40°C to +60°C

¹ Tested using 3.3V input

LED

The LED in the center of the circuit board turns on at power up and when OUT is on, as an aid to debugging.

On power up:

3 Flashes => Normal Power Up

4 Flashes => Lens is not very transmissive, but can still run at a reduced accuracy

5 Flashes => The Lens is not able to get sufficient light through for reasonable readings, it will still try to run but at a significantly reduced accuracy. This will also print a LensBad message to the RS232 interface.

J1 Connector

OUT - Open Collector Output, Pulled to ground during rain event

V+ - Input Voltage, 5 - 16 VDC

GND - Ground

J2 Connector

J2 is a pin-field on 0.1" centers, used for RS232 communication, and optionally powering the RG-9.

Connector field is 0.025" square pins on 0.1" centers. An example compatible connector is Molex part number 22-01-3067. This is available from Digi-Key as part number WM2004-ND. The necessary crimp-on wire terminals are Molex 08-55-0131 / DigiKey WM4591-ND.

J2 Pin assignments

- 1 - GND, Same as J1 GND
- 2 - V+ 5-16V, Same as J1 V+
- 3 - OUT, Same as J1 OUT
- 4 - RS232 OUT
- 5 - RS232 IN
- 6 - TB IN, Bridge to ground, normally open
- 7 - MCLR
- 8 - V+ 3.3V

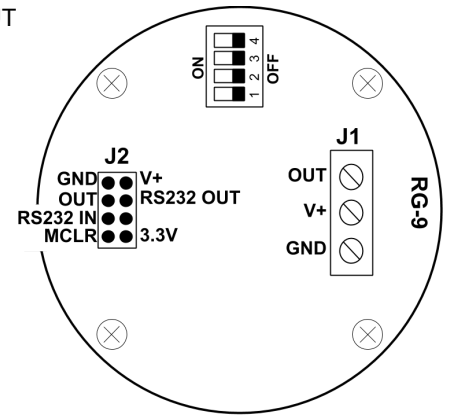

DIP Switches

1 = On, 0 = Off				Behavior
Switch 1	Switch 2	Switch 3	Switch 4	
0	0			Sensitivity 1 (Rain Drops)
0	1			Sensitivity 2 (Very Light)
1	0			Sensitivity 4 (Medium)
1	1			Sensitivity 6 (Heavy)
		0	0	Monostable Extend - None
		0	1	Monostable Extend - 5 min
		1	0	Monostable Extend - 10 min
		1	1	Monostable Extend - 15 min

Sensitivity

This is a qualitative value relative to other intensities.

Monostable Extend

This extends the Open Collector output to hold for X mins after the intensity has ended.

Accuracy

We do not claim an accuracy spec for the RG-9.

Maintenance

This is designed to be a low maintenance rain gauge. After several years (typically 7-10) the lens will need to be replaced. Replacement lenses are available on www.rainsensors.com.

RS232 Communication

The RG-9 supports communication through RS-232 at 3.3V, more information can be found at

www.rainsensors.com/rq-9-15-protocol

All lines are terminated with a carriage return followed by a new line, this is used for all output. But only the new line is required for commands. The command is processed following the new line.

Cmd (case insensitive)	Description, example response	
R	Read available data. Responses: "R 0" "R 1" "R 0 TooCold" TooCold = appended to message if it is too cold to reliably sense, this will also set the R value to 0.	
K	(Kill) Restarts the device, this will output the header, readjust the emitters and read the DIP switches again. Response: <i>Device Restarts</i>	
B <baud Code>	Set the baud rate, if none is specified responds with the current baud rate. Response: "Baud <baud rate>" <i>sent just before it is changed</i> "Baud 9600"	Baud Codes: 0 = 1200 1 = 2400 2 = 4800 3 = 9600 (Default) 4 = 19200 5 = 38400 6 = 57600
P	Set to polling only mode, outputs a new R message only when requested by the 'R' command. Response: "p"	
C	Set to continuous mode, outputs a new R message when the intensity changes. Response: "c"	

The output keywords can be comma delimited such as

"Emitters 9 10, Emtotal 19", with a space following the comma.

Output Keyword	Description, example output	
Reset	Shows the reason the device was reset.	
	Possible variations: Reset N Reset M Reset W Reset O Reset U Reset B Reset D	N = Normal Power Up M = MCLR W = Watchdog Timer Reset O = Stack Overflow U = Stack Underflow B = Brownout (Low Voltage/disconnected) D = Other
SW	Firmware version & build date Ex: SW 1.000 2020.06.05	
Emitters	Emitter 1 & 2 Levels Ex: Emitters 9 10	
EmTotal	Sum of emitters Ex: EmTotal 19	
DIP	DIP Switch positions 1234 Ex: DIP 1010	
PwrDays	How many days the device has been powered on Ex: PwrDays 13	
;	The semicolon is used to indicate that this line doesn't include any data, this is not always followed by a space. ;***** ; HYDREON MODEL RG-9 RAIN GAUGE	
LensBad	The Lens is not able to get sufficient light through for reasonable readings.	
EmSat	Emitter is saturated. Can be useful for diagnostics.	

SAFETY, LIMITS OF RAIN GAUGE LIABILITY, AND WARRANTY

Only the rain sensor is covered-- absolutely no consequential damages. If this policy is unacceptable in your installation, do not use the RG-9. Full policy can be found at www.rainsensors.com/rq-9-15-warranty.

Apply engineering judgment: Hydreon does not claim the RG-9 is a perfect rain sensor. It is what it is, and senses what it senses.

CASE and COSMETIC POLICY

Some amount of yellowing or discoloration of the case is considered normal cosmetic aging of the device, and sensors so affected will not be replaced under warranty. Tiny cracks or crazing within the lens is also considered cosmetic, and units so affected will be replaced only if they are deemed by Hydreon corporation to be of a functional nature.